

KATO

Rough Terrain Crane

KR-500

ROUGH TERR

ACS *Moment Limiter*

Lifting Capacity **50** Ton
Metric



KATO WORKS CO.,LTD.

19m Luffing Jib, infinitely variable positioning between 10° and 60°



KATO is providing New Roughterr wi

TOUGH, LONG BOOM WITH LOW DEFLECTION

The sturdy fully powered boom is designed to reduce lateral and vertical deflection during operation, providing high speed telescopic extension from 9.2m to 33.8m with single lever control. Maximum boom length with 13m fly jib is 46.8m. Maximum lifting height above ground level is 46.8 m (with 13 m fly jib). Moreover, the installation of the 19 m luffing jib gives a maximum lifting height above ground level of 53.9 m, providing unrivalled crane performance.

POWERFUL FORWARD-ACTING DERRICK CYLINDER

The powerful forward-acting derrick cylinder gives the KR-500 a wide derricking range from 0 degrees to 82 degrees. The boom heel pin is positioned behind the cab, to allow the operator a much wider range of vision and facilitate work at close quarters.

SWING-FORWARD FLY JIB

The fly jib, which is stowed alongside the main boom, can be easily swung forward into working position. This method requires far less space than is necessary for swing-around jibs. Setup is fast and simple even in restricted jobsites.

VERSATILE FLY JIB WITH 3-STAGE OFFSET

The fly jib may be set at 5°, 17°, 30° offsets to give you up-and-over reach. This feature allows the KR-500 to perform comprehensively in high-lift and close-in operations on buildings in restricted sites.

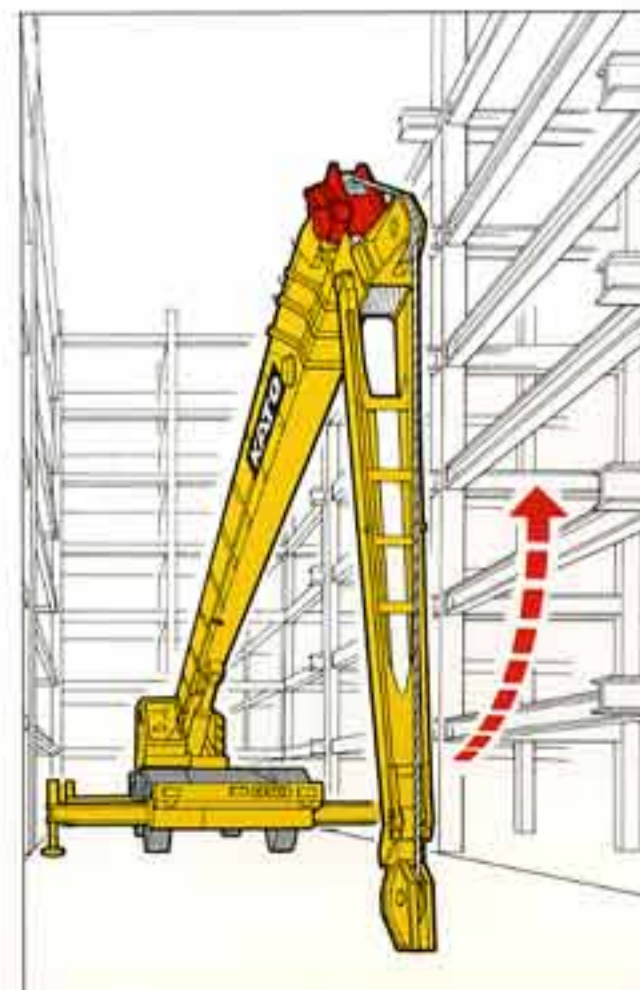

21st Century technology now! with infinitely variable offset luffing jib



THE NEWEST TECHNOLOGY FOR LUFFING SYSTEM

This rough terrain crane features an infinitely variable offset luffing jib.

The unique 19 m luffing jib arrangement makes it possible to luff at infinitely variable positions between 10 degrees and 60 degrees, whilst derricking basic boom at the same time.

The ACS moment limiter automatically compensates for the angle and length of boom, and the angle of jib, and computes back to the digital readout to advise of lifting capability.

This facilitates work at close quarters on restricted sites, as well as giving height and remote operation capabilities.

The advantage of the luffing jib arrangement is best explained in the following typical job situations, showing improved capacity over structures and ability to operate in very tight confines.

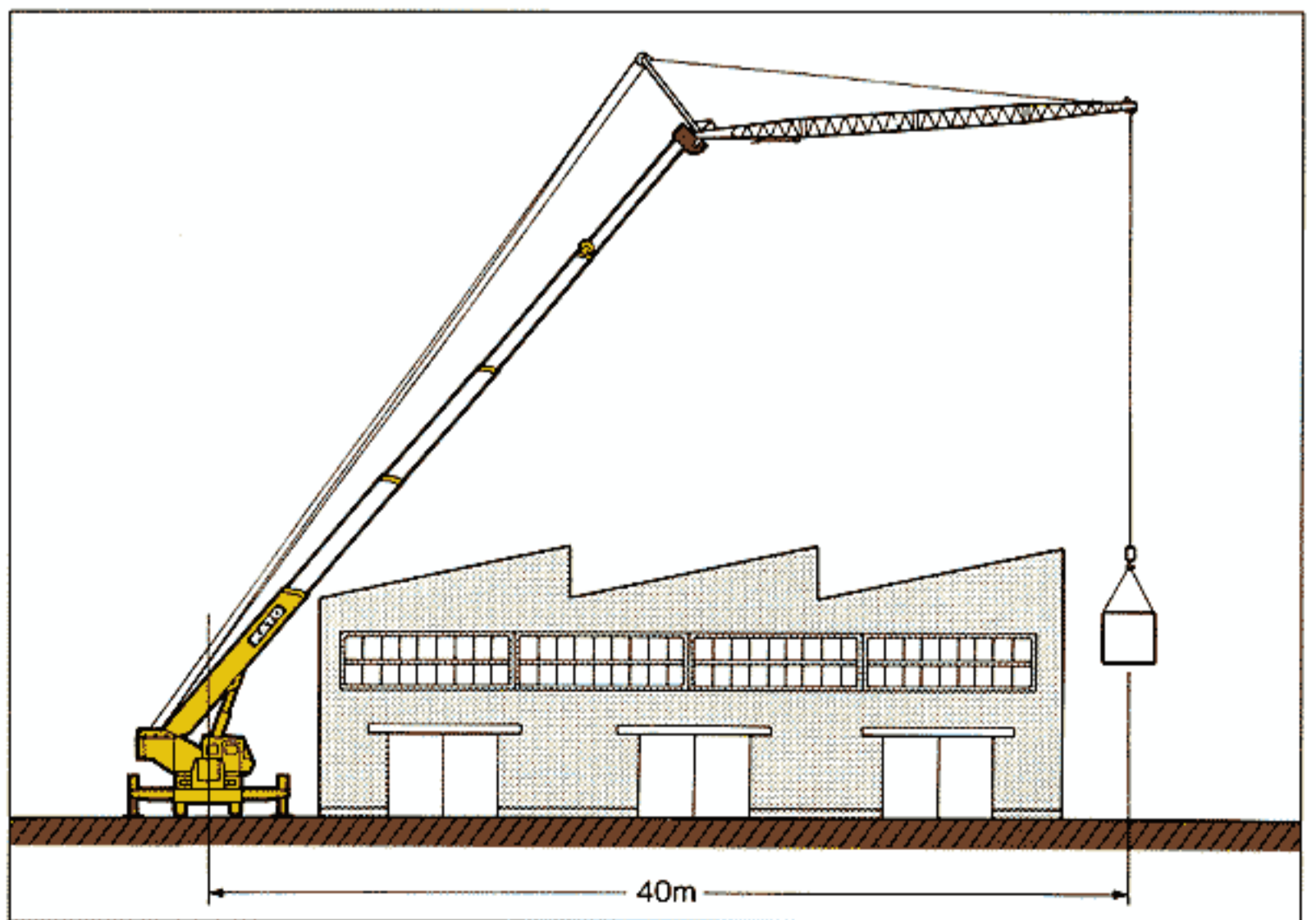
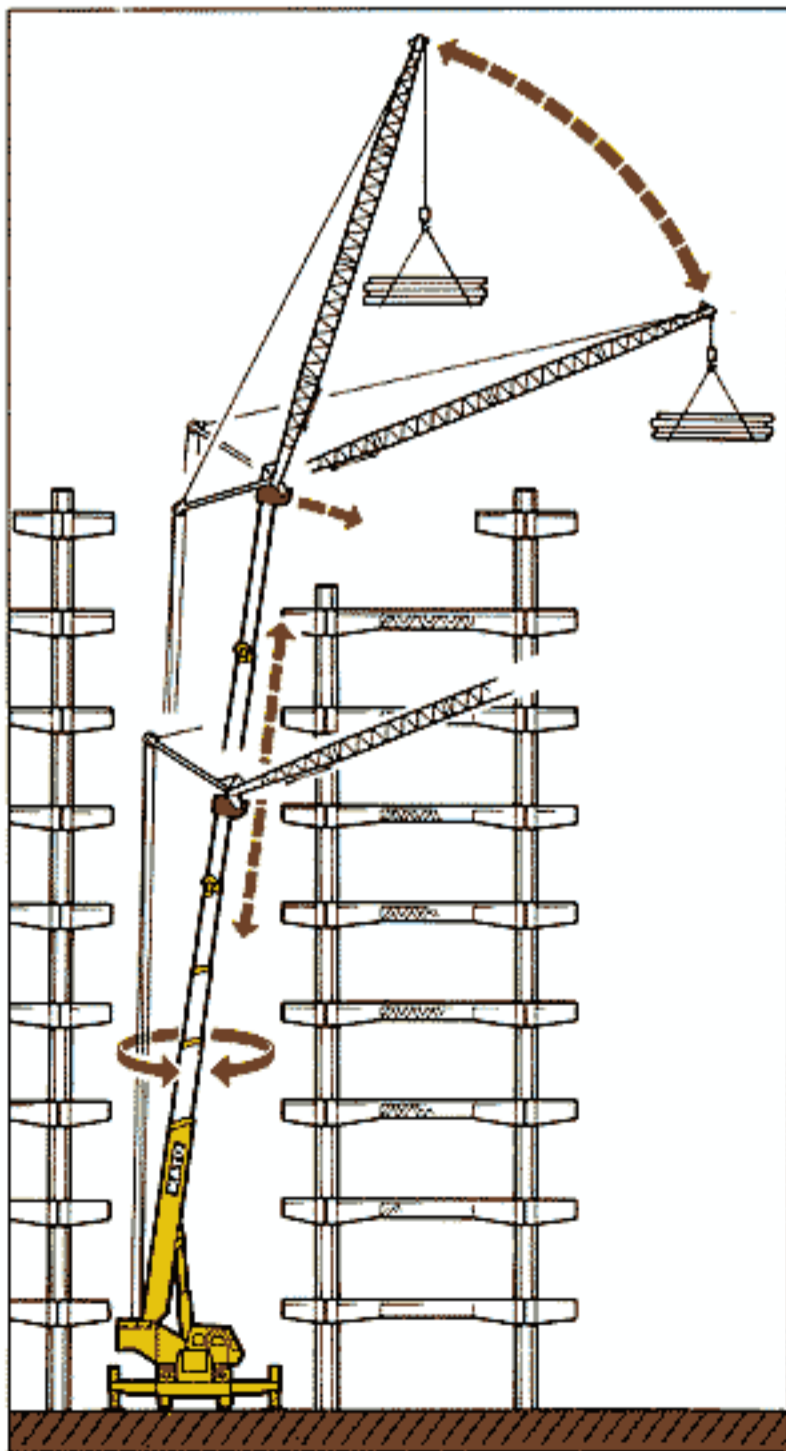
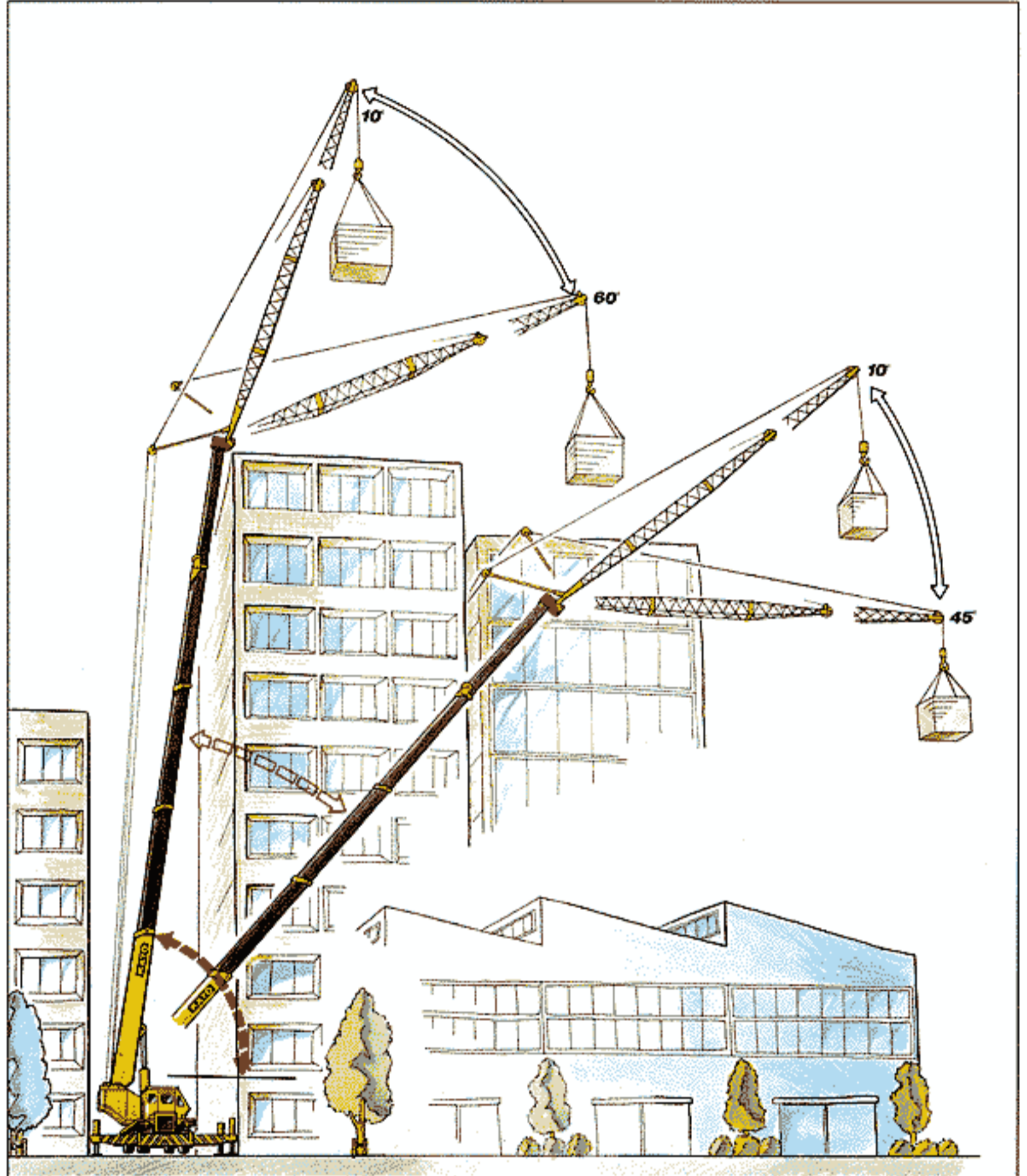

With its astonishing lifting capacity, excellent operation, the KR-500 offers unrivalled



DUAL WINCH OPERATION

The two large independently driven winches are equipped with automatic brakes. The main and auxiliary winches are operated by separate control levers and independent hoisting and lowering operations can be carried out simultaneously. The use of non-rotating ropes and large diameter winch drums, with irregular winding prevention rollers, ensures less stress on ropes and prevents ropes interwinding and tangling. This reduces wear and increases rope life.



4-PUMP SYSTEM FOR SMOOTH AND EFFECTIVE COMPOUND OPERATIONS

Three powerful independent pump systems for (hoisting, lowering), (boom derricking, telescoping), and (slewing) have been combined with a special hydraulic system to allow the KR-500 to perform the three operations simultaneously, without any loss of hydraulic power distribution. The use of the fourth pump to recharge the accumulator boosts operating efficiency.

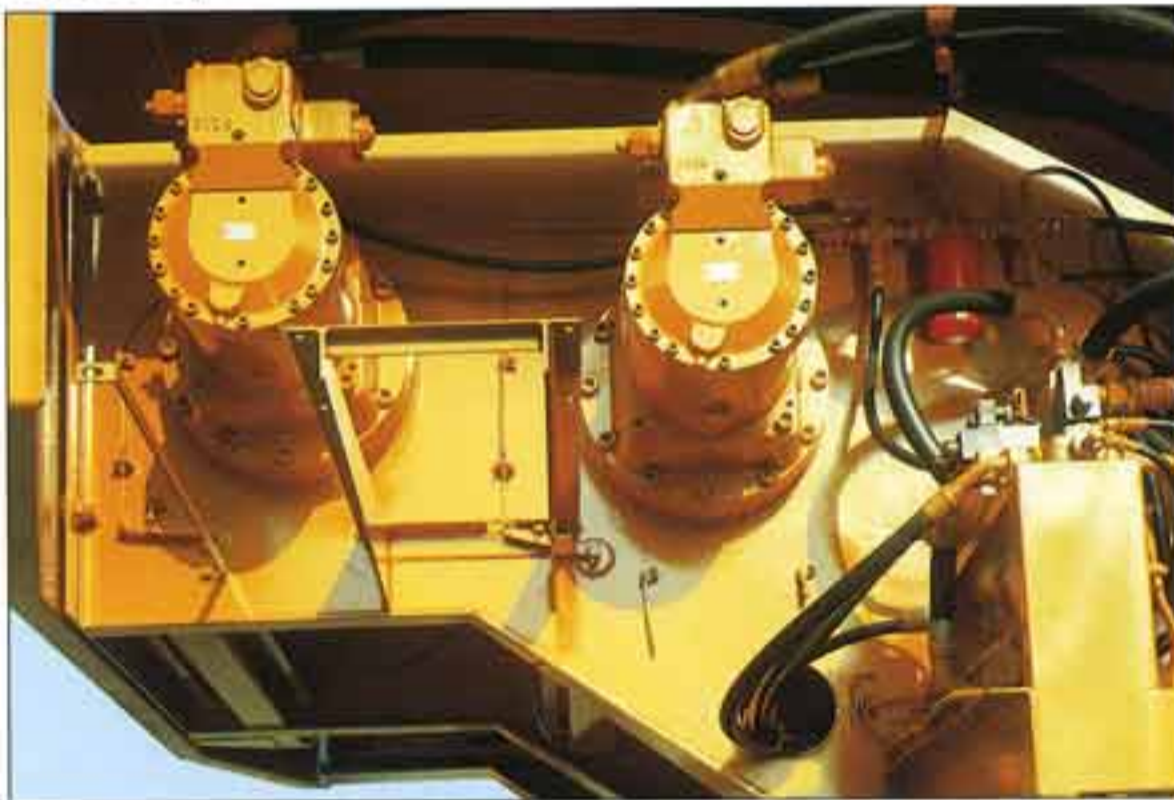

● Large main and auxiliary winches with separate motors for independent control of compound operations.



● Wide winch drums with large capacity (irregular winding prevention rollers attached).



WELL-APPOINTED CAB

The roomy 960 mm wide cab was ergonomically designed and built with full soundproofing and vibration insulation for vastly improved operator comfort. It includes van-type sliding cab door, the reclining seat, and the wiper equipped sliding window in the roof. Other features such as the heater, defroster and the door mirror provide additional superior operator comfort.



CAREFULLY DESIGNED SAFETY FEATURES

The most important hydraulic and hoisting systems are equipped with safety devices such as over-hoisting prevention system, a slewing lock, automatic winch brakes, outrigger locks and hydraulic relief valves.



● Functional and spacious cab



● Levers can be positioned to allow the operator easy access to the cab.

Extensive working range and superior performance

MICROCOMPUTER-CONTROLLED ACS MOMENT LIMITER

The ACS moment limiter is an automatic overload prevention device, incorporating calculation functions based on state-of-the-art electronic technology to monitor all safety factors. It provides precise digital readout of up to 8 safety factors: namely, safety level, luffing jib angle, boom angle, working radius, boom length, critical load, actual load, and maximum hook lift.

Outrigger status can also be input with the selection switch. Even when left and right outriggers are extended to different lengths, the ACS moment limiter automatically compensates for the varying safe working loads.

The voice alarm reminds the operator to make preliminary checks and warns of overloads and other problems.

In the event of system defect, the  symbol will light up and digital read-out will indicate the part affected.

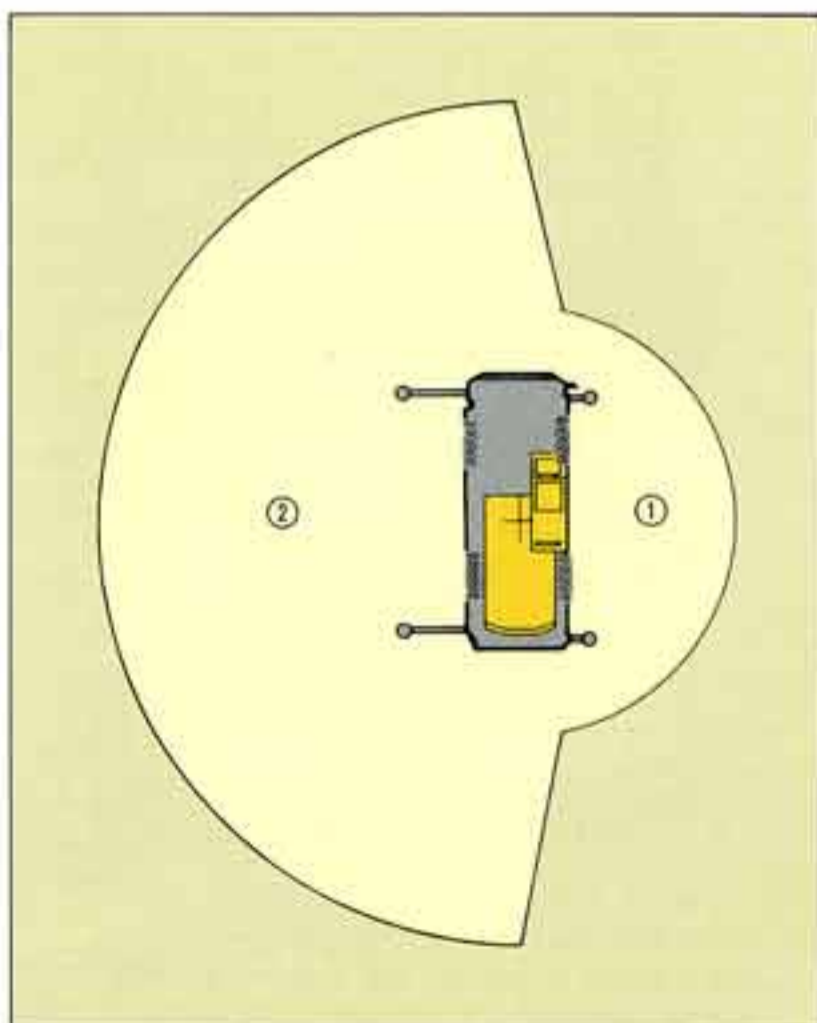

- ① Working range at intermittent stroke
- ② Working range at maximum stroke

MINIMIZED TAIL-SLEWING

Since the tail slewing radius of superstructure is only 3.3 m from slewing center with counterweight, the crane can slew easily and efficiently within the fully extended outrigger span of 7.3 m.

SLEWING SYSTEM WITH FREE/LOCK SWITCHING

The operator can select a free slewing stop for normal repetitive work, or lock slewing stop for high-lift operations and heavy work. The hydraulic slew brake is also provided for extra safety.

FOUR-POSITION OUTRIGGERS

The KR-500 comes with H-type outriggers that can be extended to four operating positions: 7.3 m, 5.5 m, 4.0 m, and 2.59 m. The extension span suitable for site conditions can be selected to allow optimum operation, with any of 4 positions to either side of crane.

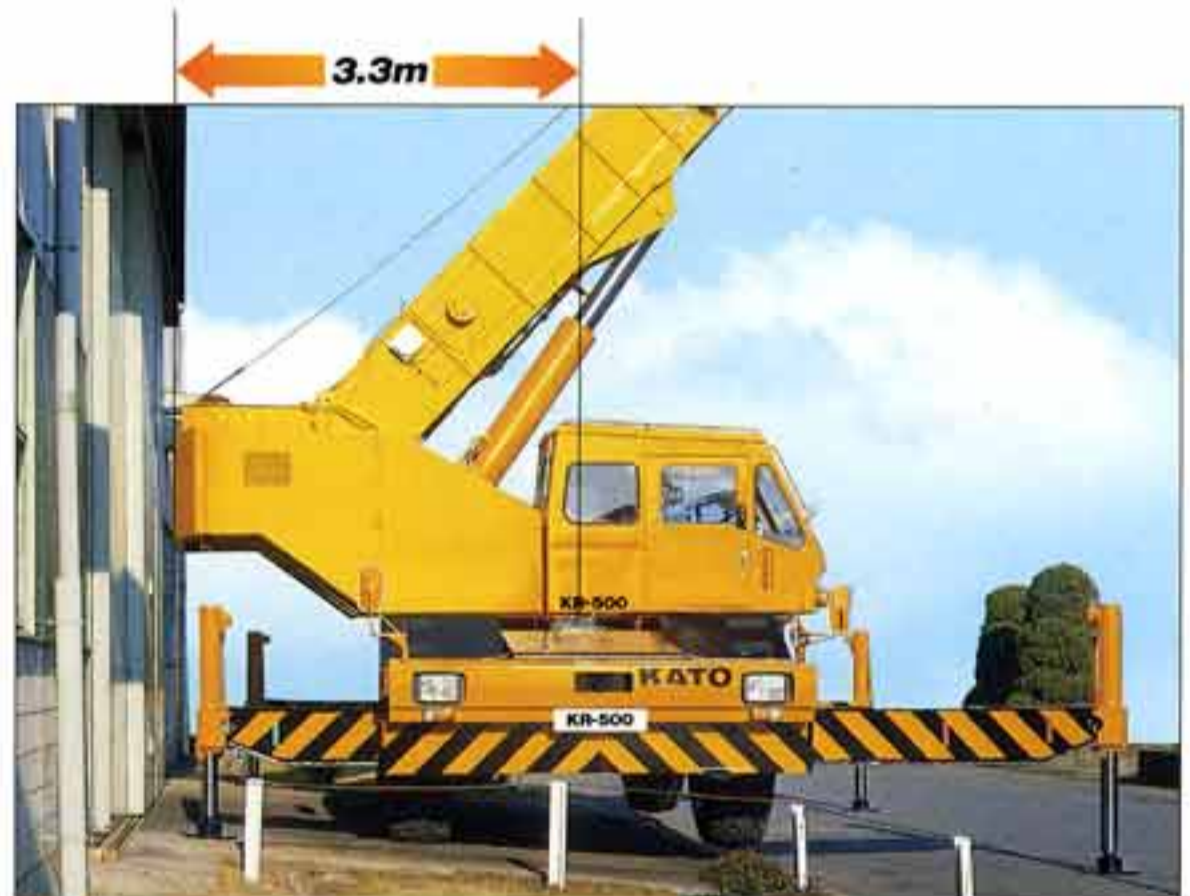

Further proof of Kato's continuing lead



UNPRECEDENTED SPEED AND POWER

The powerful turbocharged 270PS engine drives a transmission equipped with high and low speed selection and 3 speed gearing. The driver may select the most appropriate speed for any particular road condition from among the 6 forward and 6 reverse speeds.

The use of sprung suspension equipped with the anti-dive device has allowed the KR-500 to improve top speed traveling to 53 km/h. This factor improves performance and productivity with the ability to travel quickly from job to job on site. Furthermore, it improves driver comfort and reduces fatigue.

SUPERB TRAVEL AT HIGH SPEED

Kato has developed a new axle with kingpin offset and camber angles. The wheels slightly toed in to allow fast travel without wheel wobble, and sit and steer firmly without the continual chasing of steering wheel experienced in the conventional rough terrain cranes.

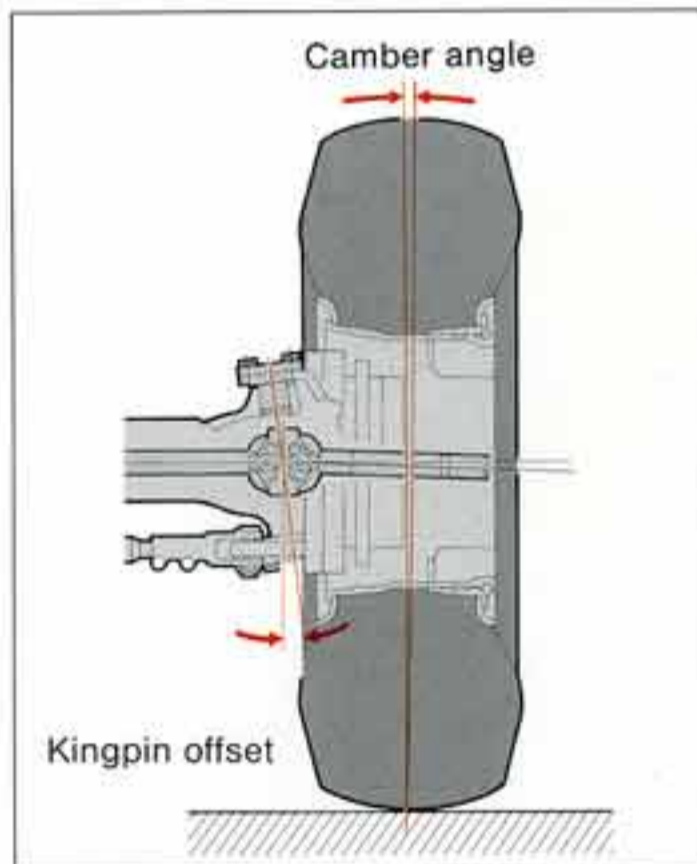

3-STEERING MODES ENSURE EASY TURNING

The operator can select 2-wheel drive, 4-wheel coordinated circle steering, or crab steering from the cab. In spite of its long 4.25 m wheelbase, the minimum turning radius is a mere 6.2 m in 4-wheel co-ordinated steering mode.

INNOVATIVE REVERSE STEERING CORRECTION MECHANISM

The reverse steering correction mechanism allows the same steering operation whether the superstructure is facing forwards or backwards.

This handy mode lets the operator steer in the direction of travel regardless of which direction the superstructure faces.

STEADY PICK AND CARRY

The suspension may be locked from inside the cab with the flick of a switch. The sturdy carrier frame and heavy-duty tires with huge load-bearing capacities provide steady base for pick-and-carry duties.

TOUGH OFF-THE-ROAD TIRES

The KR-500 is equipped with heat-resistant off-the-road tires <18.00-25-28 PR (OR)> that possess enormous load-bearing capacities. They provide power and grip for pick-and-carry operations on unimproved ground as well as being suited for traveling on soft ground and rugged terrain.

• The reverse steering correction mechanism

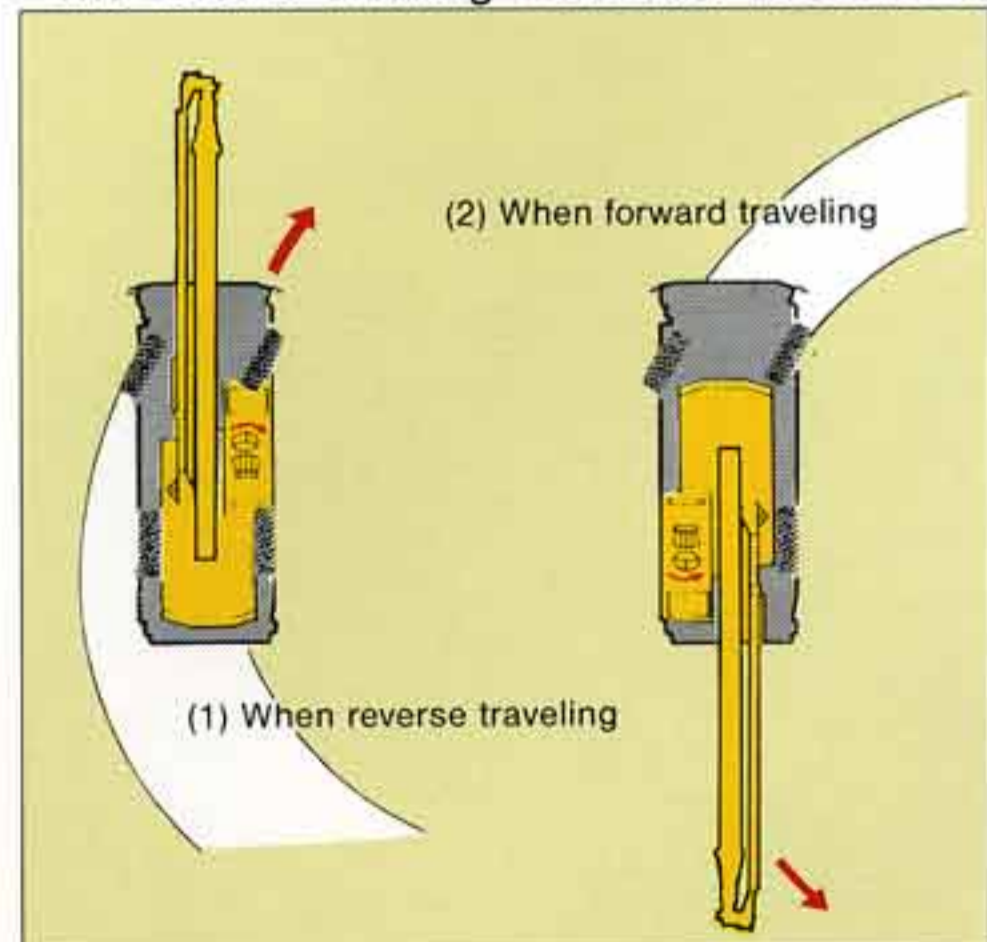

- (1) Forward travel: normal steering.
- (2) Reverse travel: When the superstructure advances in that direction, the operator can select the reverse steering correction mechanism at will so that the vehicle will turn in the same direction as the steering wheel.

ership and technological superiority

OUTSTANDING BRAKING POWER

Front and rear wheels are equipped with disc brakes and exhaust brakes that feature excellent heat dispersion and outstanding braking power. Solid braking power is guaranteed when frequent stopping is required in city traffic and especially on long downward slopes.

RELIABLE PARKING BRAKE

A new parking brake has been provided with a service brake lock. This ensures reliable parking and effective operating capacity on sloping ground.

LARGE HEADLAMPS

Bright rectangular halogen headlamps ensure safe nighttime driving.

OVERHANG MANOEUVERABILITY

The 5 section boom enables a short basic section 9.2 m, whilst allowing a long fully powered extension to 33.8 m. Further advantage of this short basic boom is a relatively short overhang over front from the front axle. This allows considerably improved manoeuvrability and vision when traveling.

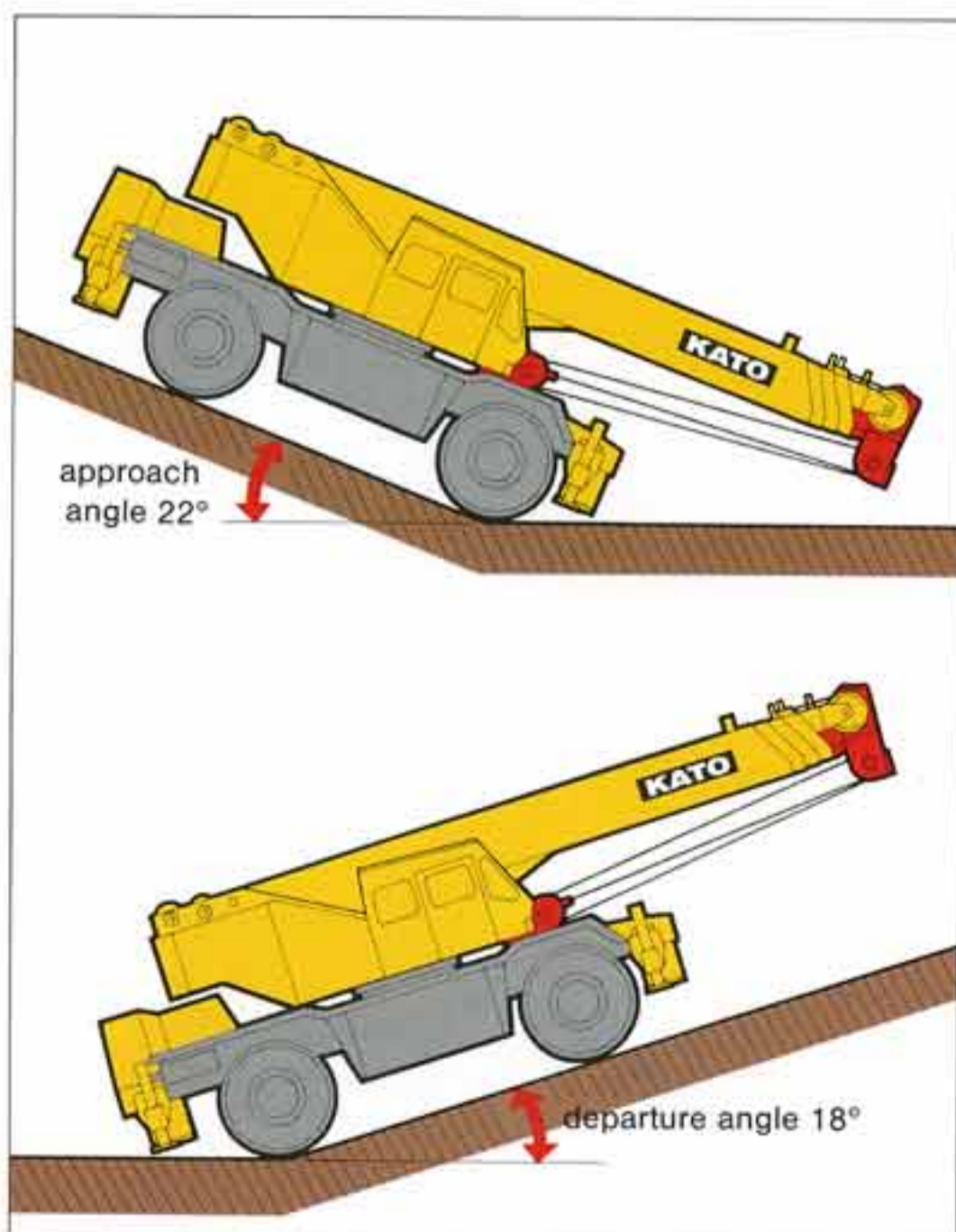

GETS INTO CRAMPED WORKING AREAS WITH EASE

With larger angles of approach and departure, the KR-500 can traverse uneven terrain easily. The fully spring axles with anti-dive device allow smooth travel on inclined, uneven, or soft roads surface.

SAFETY FEATURES WHILE TRAVELING

For safety while traveling, and overshift prevention device has been installed together with an emergency steering system, a rear-wheel steering system, a rear-wheel steering lock device, a fluid level warning buzzer, and a suspension lock device, all to prevent any conceivable problems arising.

EASY INSPECTION AND MAINTENANCE

The engine, torque converter, and transmission are solidly constructed and use highly durable and reliable parts for easy maintenance. Starting with the engine cover, close attention has been paid to providing easy access for inspection of each part for maintenance and lubrication purposes.



The following items of equipment, which are mentioned in the catalog and appear in the illustrations, are all options.

- Fly jib
- Luffing jib
- Auxiliary winch drum
- auxiliary winch motor
- Wire rope and hook for auxiliary hoist
- Rooster sheave
- Voice alarm device for ACS moment limiter
- Heater
- Defroster

KR-500

ROUGHTERR



NOTE: Illustrations may include optional equipment. KATO products and specifications are subject to improvements and changes without notice.



KATO WORKS CO.,LTD.

9-37, Higashi-ohi 1-chome, Shinagawa-ku, Tokyo 140, Japan
Tel. : Head Office Tokyo (03) 3458-1111
Overseas Marketing Department Tokyo (03)3458-1115
Telex : 0222-4519 (CRKATO J)
Fax. : Tokyo (03) 3458-1151
Cable : CRANEKATO TOKYO